

# Voltage Transducer LV 100-4000/SP6

For the electronic measurement of voltage: DC, AC, pulsed..., with galvanic separation between the primary circuit and the secondary circuit.

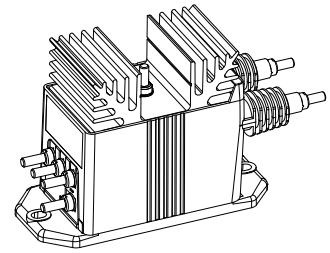

$$V_{PN} = 4000 \text{ V}$$



## Electrical data

$V_{PN}$	Primary nominal rms voltage	4000	V				
$V_{PM}$	Primary voltage, measuring range	0 .. ±6000	V				
$I_{PN}$	Primary nominal rms current	2.5	mA				
$R_M$	Measuring resistance	$R_{M \min}$	$R_{M \max}$				
					with ±15 V	@ ±4000 V <sub>max</sub>	0
			@ ±6000 V <sub>max</sub>		0	120	Ω
		with ±24 V	@ ±4000 V <sub>max</sub>		0	410	Ω
			@ ±6000 V <sub>max</sub>		110	250	Ω
$I_{SN}$	Secondary nominal rms current	50	mA				
$K_N$	Conversion ratio	4000 V / 50	mA				
$U_C$	Supply voltage (±10 %)	±15 .. 24	V				
$I_C$	Current consumption	<37(@ ±24V) + $I_S$	mA				

## Accuracy - Dynamic performance data

$X_G$	Overall accuracy max. <sup>1)</sup> @ $V_{PN}$ , $T_A = 25 \text{ °C}$	±1.0	%	
		@ $T_A = -25 \text{ °C} .. +70 \text{ °C}$	±2.2	%
		@ $T_A = -40 \text{ °C} .. +85 \text{ °C}$	±3.0	%
$\epsilon_L$	Linearity error maximum	±0.1	%	
$I_O$	Offset current @ $I_P = 0$ , $T_A = 25 \text{ °C}$	Typ	Max	
			±0.2	mA
$I_{OT}$	Temperature variation of $I_O$	-25 °C .. +70 °C	±0.4	mA
		-40 °C .. +85 °C	±1.0	mA
$t_r$	Step response time to 90 % of $V_{PN}$ <sup>2)</sup>	200	µs	

## General data

$T_A$	Ambient operating temperature	-40 .. 85	°C	
$T_S$	Ambient storage temperature	-50 .. 90	°C	
$N_P/N_S$	Turns ratio	40000 : 2000		
$P_P$	Total primary power loss	10	W	
$R_1$	Primary resistance	@ $T_A = 25 \text{ °C}$	1.6	MΩ
$R_S$	Resistance of secondary winding	@ $T_A = 85 \text{ °C}$	57	Ω
$m$	Mass	820	g	
	Standards <sup>3)</sup>	EN 50155: 1995		

- Notes:**
- The overall accuracy is ±6 % at ambient temperature -50 °C, including a maximum offset drift 2.2 mA
  - With a di/dt of 100 A/µs
  - IEC 61000-4-3: connect the internal shield "E" to the ground to fulfill 20 V/m from 80 MHz to 1 GHz.

## Features

- Closed loop (compensated) voltage transducer using the Hall effect
- Insulating plastic case recognized according to UL 94-V0
- Primary resistor  $R_1$  incorporated within the housing.

## Special features

- $U_C = \pm 15 .. 24 (\pm 10 \%) \text{ V}$
- $U_d = 12 \text{ kV}$  (to see note, page 2)
- $U_d = 2 \text{ kV}$  (to see note, page 2)
- $T_A = -40 \text{ °C} .. +85 \text{ °C}$
- Connection to primary circuit by extra-long studs
- Connection primary and to secondary circuit on M5 threaded studs
- Shield between primary and secondary.

## Advantages

- Excellent accuracy
- Very good linearity
- Low temperature drift
- High immunity to external interference.

## Applications

- Single or three phase inverters
- Propulsion and braking choppers
- Propulsion converters
- Auxiliary converters
- Battery chargers.

## Application Domain

- Traction.

## Voltage Transducer LV 100-4000/SP6

### Insulation coordination

$U_d$	Rms voltage for AC insulation test, 50 Hz, 1 min	12 <sup>1)</sup>	kV
		2 <sup>2)</sup>	kV
$\hat{U}_w$	Impulse withstand voltage 1.2/50 $\mu$ s	34	kV
		Min	
$d_{cp}$	Creepage distance	164.8	mm
$d_{cl}$	Clearance	47.1	mm
$CTI$	Comparative Tracking Index (group I)	600	

Notes: <sup>1)</sup> Between primary and secondary + shield + heatsink

<sup>2)</sup> Between shield and secondary + heatsink.

### Safety



This transducer must be used in electric/electronic equipment with respect to applicable standards and safety requirements in accordance with the manufacturer's operating instructions.



Caution, risk of electrical shock

When operating the transducer, certain parts of the module can carry hazardous voltage (eg. primary connections, power supply).

Ignoring this warning can lead to injury and/or cause serious damage.

This transducer is a build-in device, whose conducting parts must be inaccessible after installation.

A protective housing or additional shield could be used.

Main supply must be able to be disconnected.

## Dimensions LV 100-4000/SP6 (in mm)

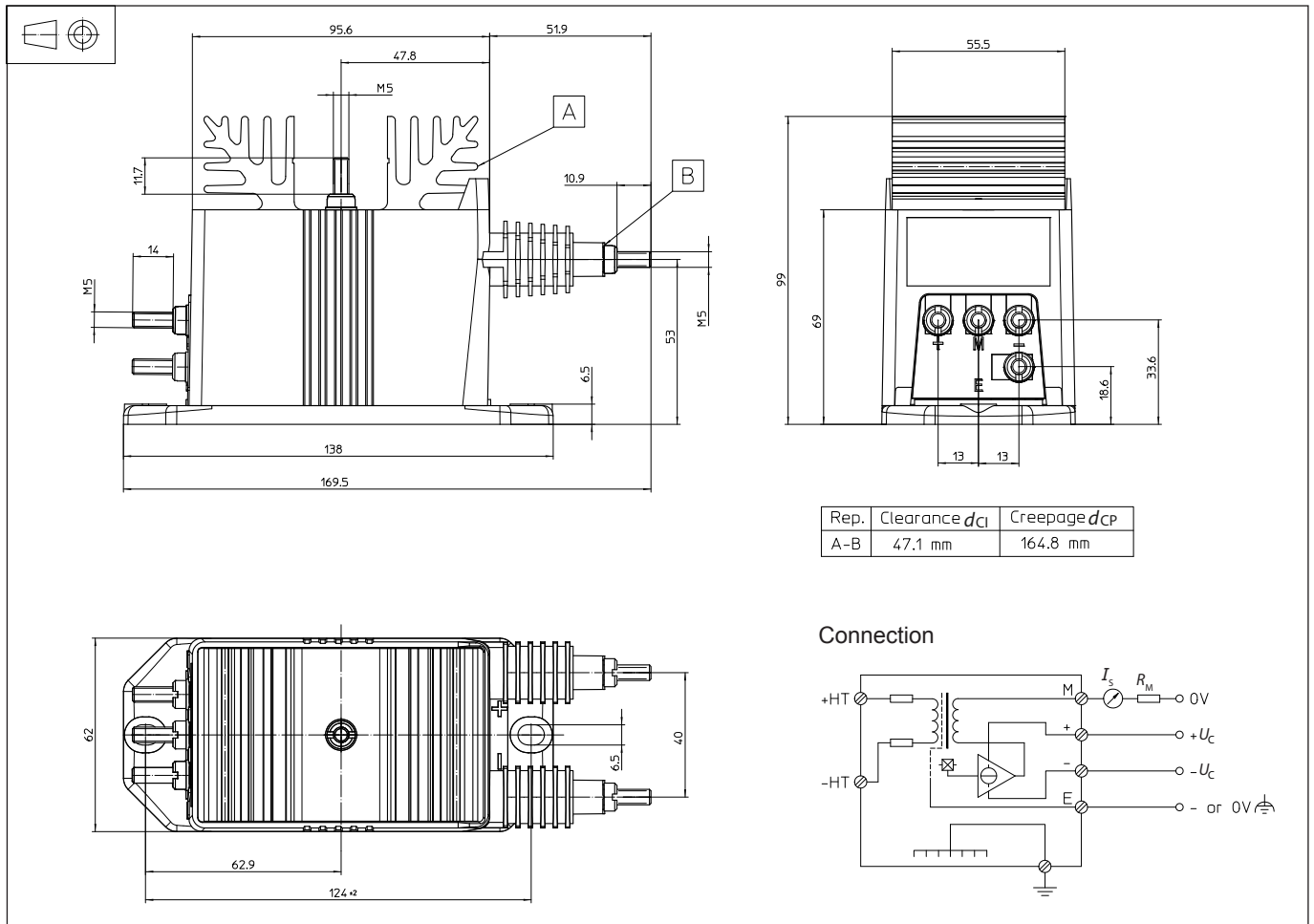

### Mechanical characteristics

- General tolerance  $\pm 0.3$  mm
- Transducer fastening
  - 2 holes  $\varnothing 6.5$  mm
  - 2 M6 steel screws
- Recommended fastening torque 5 N·m
- Connection of primary 2 M5 threaded studs
- Connection of secondary 4 M5 threaded studs
- Connection to the ground M5 threaded studs
- Recommended fastening torque 2.2 N·m

### Remarks

- $I_s$  is positive when  $V_p$  is applied on terminal +HT.
- Installation of transducer is to be done without primary or secondary voltage present.
- Installation of the transducer must be done unless otherwise specified on the datasheet, according to LEM Transducer Generic Mounting Rules. Please refer to LEM document N°ANE120504 available on our Web site: [Products/Product Documentation](#).